

M-SERIES G-II BURNER HEAD REPLACEMENT KITS

⚠ WARNING

Ensure coolant system is cool and not pressurized before starting work.

⚠ WARNING

Shock hazard due to high voltage.

⚠ WARNING

Burn hazard due to high temperature.

NOTICE

For more information on the G-II PCM, visit www.proheat.com and review product update bulletin PB0038.

Figure A.

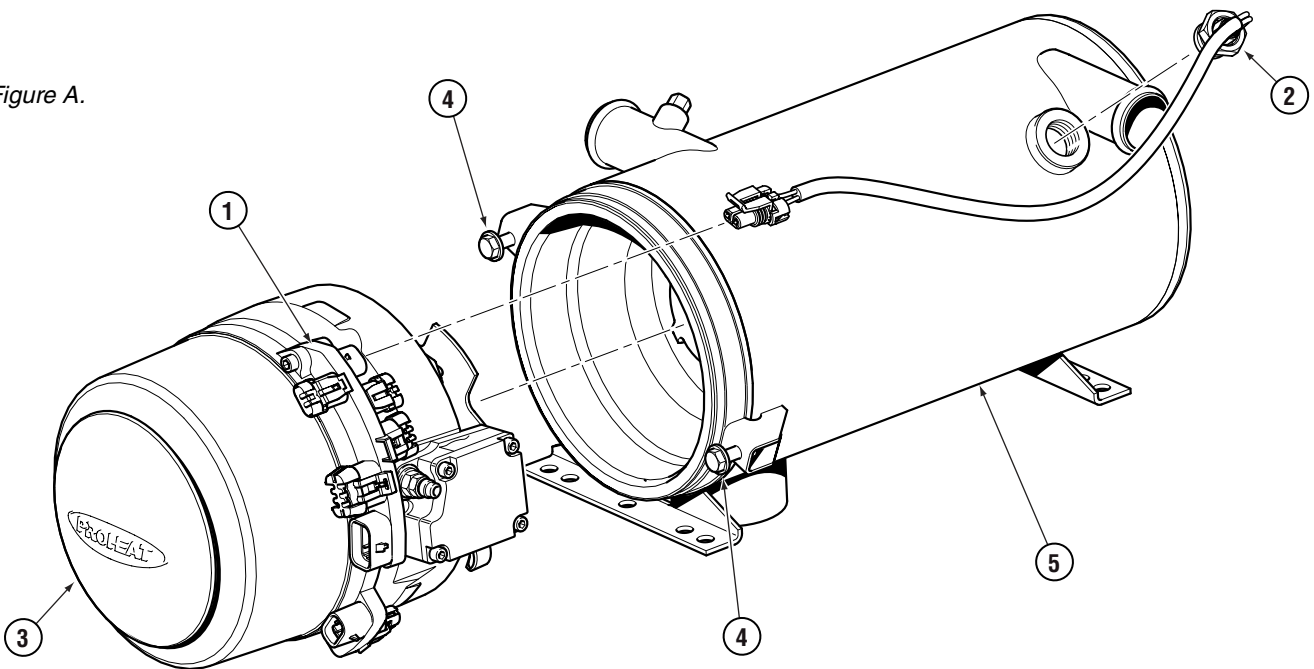

Removal/Disassembly of Existing Burner Head and Temperature Sensor (Two Wire)

1. Before proceeding, ensure coolant system is cool and not pressurized.
2. Disconnect all harnesses at the PCM (item 1).
3. Isolate the heater coolant by clamping off heater inlet and outlet hoses or by turning off the coolant valves to the heater (if present).
4. Disconnect and cap fuel line.
5. Remove and discard the temperature sensor (item 2) by unscrewing the hex adaptor (item 2) at the heat exchanger (item 5).
6. Remove burner head (item 3) by loosening the mounting bolts (item 4) five to six turns and rotating the burner head 15° counter-clockwise and separating from the heat exchanger (item 5).

NOTICE

Isolating the heat exchanger coolant volume minimizes coolant loss. Collect coolant as per local regulations.

Check Heat Exchanger and Combustion Tube

After removing the burner head (item 1). Check the heat exchanger (item 2) and combustion tube (item 3) for excessive combustion deposits.

1. Remove the combustion tube (item 3) to access the inside of the heat exchanger (item 2).
2. To maintain optimum heat output and operation, clean any combustion deposits that may have accumulated on the heat exchanger (item 2) fins.
3. Use a wire brush to loosen and remove the deposits.
4. Ensure exhaust pipe (item 4) is clean and free from restriction.
5. Install the combustion tube (item 3) into the heat exchanger (item 2) ensuring that the combustion tube orientation boss is aligned with the heat exchanger flange notch as shown in Fig. B.

WARNING

A suitable mask should be worn when cleaning the combustion tube to ensure dust from combustion deposits is not inhaled.

Figure B.

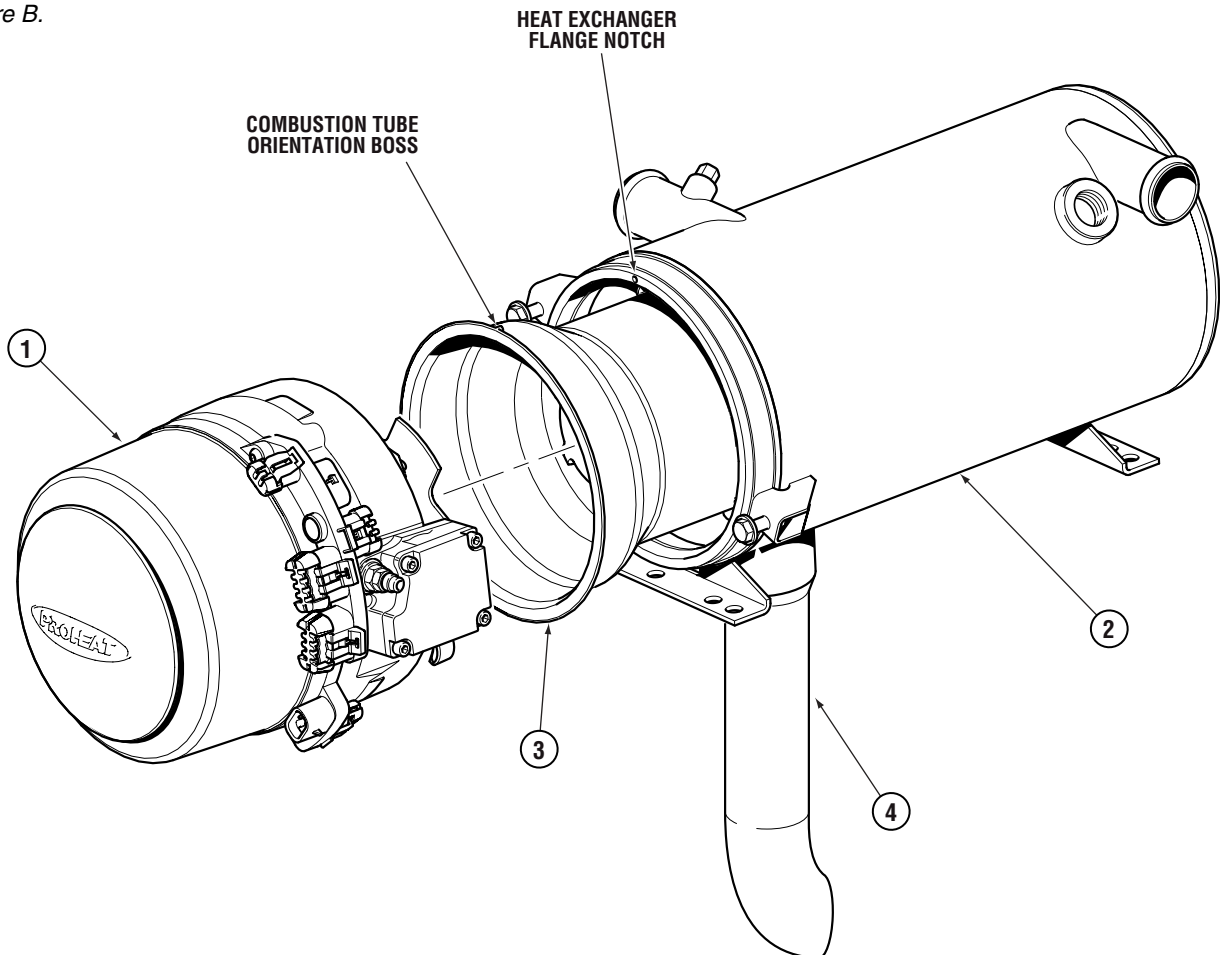



INSTALLATION INSTRUCTIONS

Copy Part# 204501, Rev. B, 05/2014

Page 3 of 4

New Burner Head & Dual Mode Temperature Sensor (Four Wire) Reassembly

1. Install the new dual mode temperature sensor (item 2) by screwing in the hex adaptor (item 2) into the heat exchanger (item 5) and torquing as shown in Fig. C. Remove coolant hose clamps or open valves to allow coolant to flow through the heater.

NOTICE

DO NOT power heater but run engine and heating system to get coolant flowing if required. Ensure heater is filled with coolant.

2. Check system coolant level. Refill if required.
3. Install new burner head (item 3) and fuel line. Tighten mounting bolts (item 4) and torque as per Fig. C.
4. Reconnect all harnesses to the PCM (item 1) and operate for a minimum of two cycles to ensure functionality. Inspect for any coolant or fuel leaks around exterior of burner head and heat exchanger.

NOTICE

If auxiliary connector (item 6) was used on the G-I PCM please see Page 4 – Optional Auxiliary Connector Replacement Instructions.

Figure C.

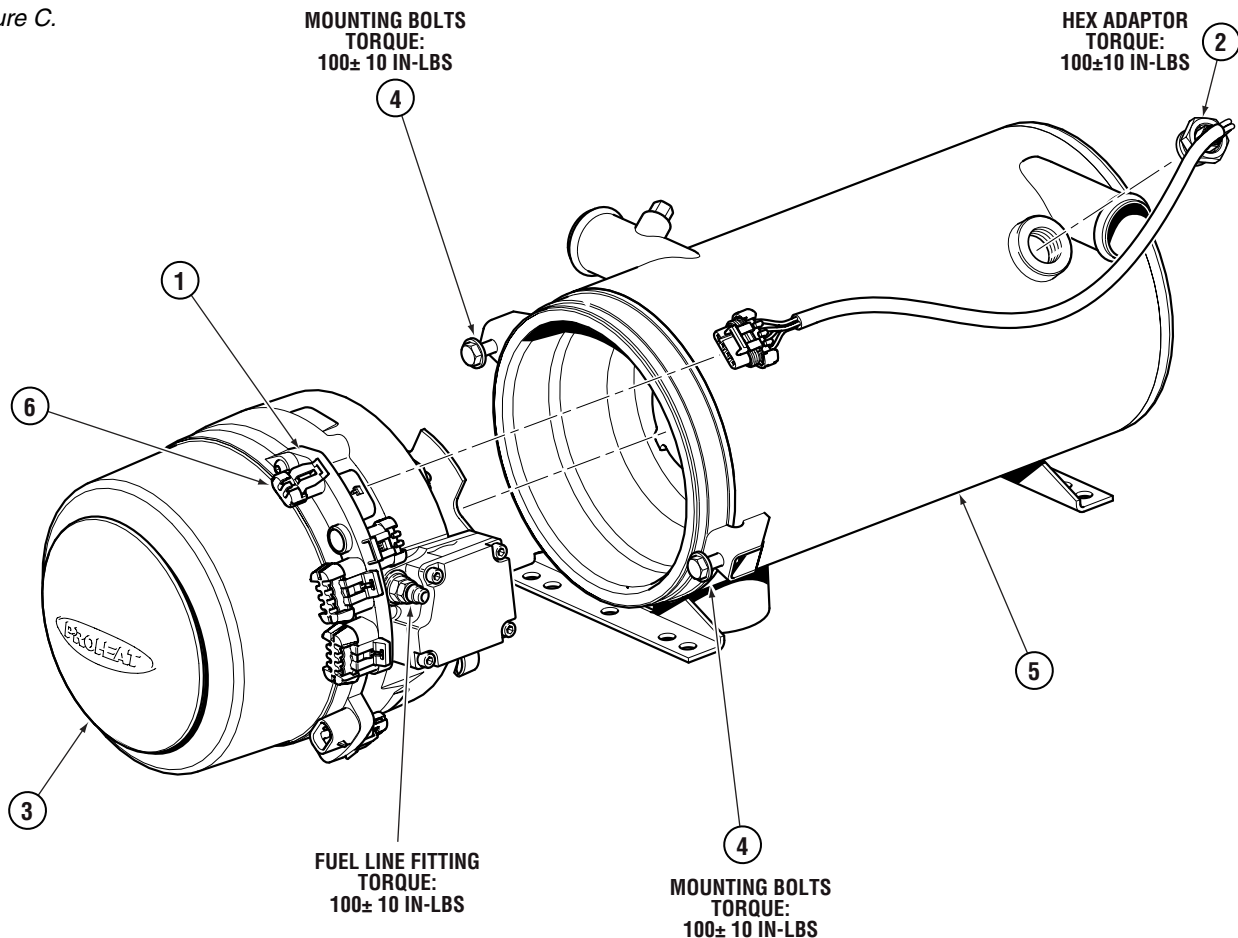

OPTIONAL Auxiliary Connector Replacement Instructions

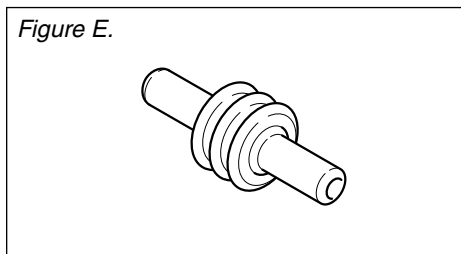
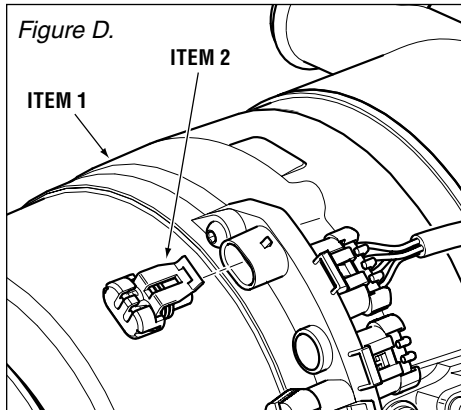

If the auxiliary output was used on the old G-I PCM, the connector on the vehicle harness will need to be changed in order to fit into the new G-II PCM auxiliary port. For this procedure, please follow the steps outlined below.

The new G-II PCM (item 1) comes with the required auxiliary connector (item 2) already inserted into the auxiliary port. Before proceeding, remove this connector from the PCM as shown in Fig. D.

STEP 1. Using a small flat head screwdriver, disconnect the TPA (terminal protection assurance) from BOTH the new and existing connector bodies, then remove the two red rubber plugs (Fig. E) from the new auxiliary connector (Fig. D, item 2).

STEP 2. Insert terminal removal tool (Fig. F, item 3) into both terminal recesses of the existing connector body as shown in Fig. F, then pull out the two wires. Take note of which wire was inserted in terminal 'A' and terminal 'B' (see Fig. F inset) as these will have to line up the same way on the new auxiliary connector (Fig. F, item 2).

STEP 3. Using a small screwdriver, carefully lift up the tab on the back of both terminals so that they sit proud as shown in Fig. F.

STEP 4. Ensure both wires are lined up with the correct 'A' & 'B' terminal on the new auxiliary connector as noted above and shown in Fig. F inset.

STEP 5. Push both wires into the new auxiliary connector (item 2) until they click into place. Pull back on both wires firmly to ensure they are fully seated in the connector body. If seated correctly, the wires should not pull out. **NOTE:** If only one wire is used, ensure a red rubber plug (see Fig. E) is inserted into the unused terminal.

STEP 6. Replace the TPA over the new auxiliary connector body, ensuring it clicks into place. Discard old connector body.

