

# HIGH-IDLE GOVERNORS

Installation Instructions  
and  
Trouble-shooting Guide

## Models Covered:

for 12 Volt systems  
TR1001 for Power Take Off use  
TR2001 for Fast Idle use

for 24 Volt systems  
TR1241 for Power Take Off use  
TR2241 for Fast Idle use

Each governor comes complete with an installation kit which contains all necessary components for installation on all Cummins NH-NT Small Cam engines and NT Big Cam engines. Other engines may require substitutions and/or modification of the mounting bracket.

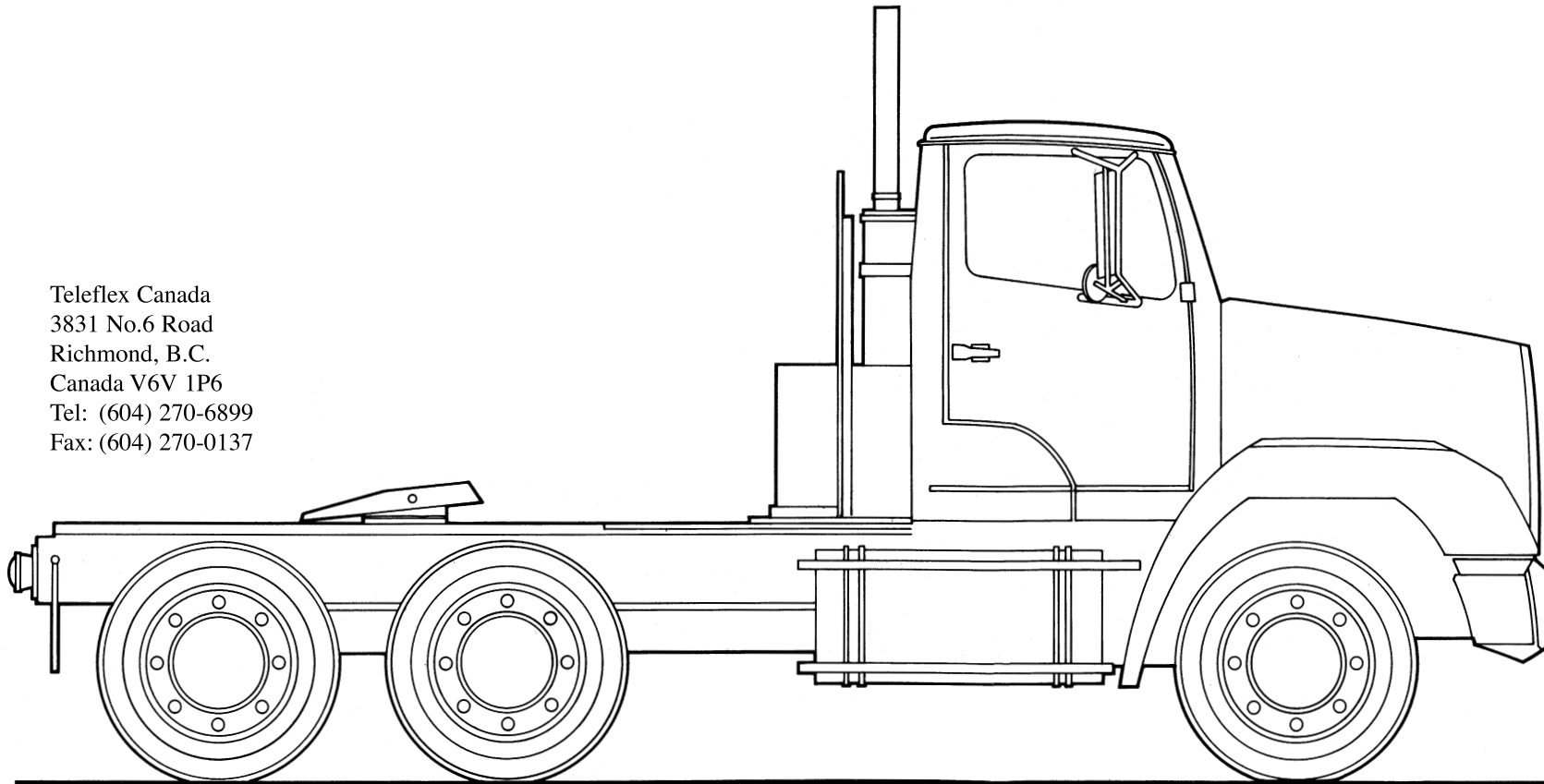

Teleflex Canada  
3831 No.6 Road  
Richmond, B.C.  
Canada V6V 1P6  
Tel: (604) 270-6899  
Fax: (604) 270-0137

Printed in Canada

## Content

	Description .....	1
	Warning .....	1
	Function .....	2
<b>SECTION 1.</b>	<b>INSTALLATION.</b> .....	<b>4</b>
	Preparation .....	4
	Mounting .....	5
	Fuel Pump .....	6
	Drain .....	8
	Hoses .....	9
	Wiring .....	10
	Start up .....	14
<b>SECTION 2.</b>	<b>TROUBLE SHOOTING.</b> .....	<b>15</b>
<b>SECTION 3.</b>	<b>REPAIRS.</b> .....	<b>17</b>
<b>SECTION 4</b>	<b>PARTS LIST.</b> .....	<b>25</b>
	TR 1001 & TR 1241 .....	26
	TR 2001 & TR 2241 .....	27
	Warranty Information .....	28

## Description

The Teleflex High Idle Governor works exclusively on all Cummins engines with PT fuel systems (excluding B and C series). The governor maintains engine RPM at a steady pre-set speed and automatically compensates for load changes by regulating the flow of fuel to the injectors. It has been designed for use while the truck is stationary with applications such as PTO or “Fast Idle”. It is not intended for highway operations such as cruise control.

## Warning

Before proceeding with the installation, read these instructions thoroughly. Teleflex cannot accept responsibility for installations where instructions have not been followed, where substitute parts have been used, or where modifications have been made to our products.

**WARNING**—*HIGH IDLE governors are not intended to be used for any form of road speed control. If the governor will be operated while the vehicle is in motion, install an electrical interlock with the brake system, such that when the brakes are applied, the governor is automatically switched off and will not operate again until it is manually reset.*

# Function

1. The governor senses engine speed indirectly with fuel pressure from the gear pump, inside the fuel pump. Fuel pressure increases proportionately with engine speed. This pressure exerts a force on the outer end of the plunger, closing the fuel metering port. The governor spring forces the plunger in the opposite direction which opens the fuel metering port. In operation, the pressure and spring forces balance positioning the plunger so that there is only enough fuel flow to maintain the required engine speed.

The governor compensates for load changes in this manner:

- a) load demand increases; example: PTO switched on.
- b) engine speed drops slightly.

- c) gear pump fuel pressure decreases.
- d) spring forces plunger to left, increasing metering port opening.
- e) governor sends more fuel to engine injectors.
- f) engine power output increases until it matches the load.

2. The governor is equipped with a shut off valve. This is a solenoid type valve which operates electrically. It has two positions: open, allowing free flow of fuel, or closed. The valve does not meter flow.
3. As a safety precaution, inlet fuel to the High-Idle Governor is taken after the Cummins automotive governor. The automotive governor limits the maximum engine speed regardless of misadjustment or failure of the High-Idle Governor.

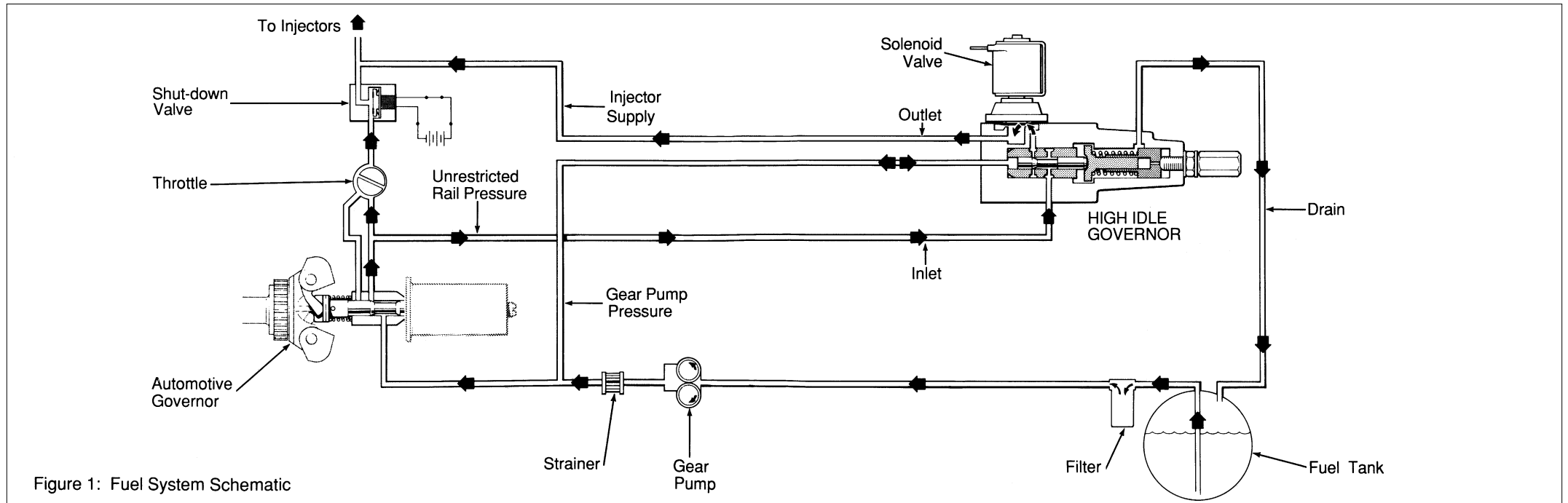

Figure 1: Fuel System Schematic

# 1. INSTALLATION

## Preparation

Cleanliness is essential for the proper function of the fuel system. It is important to thoroughly clean the engine and fuel pump before proceeding.

## Mounting

1. The mounting bracket has been designed so that the governor can be attached in four different positions. See figure 2.
2. Install the governor on the engine behind the fuel pump. The exact location is to be determined by the existing equipment and brackets.
3. Normal installation has the governor horizontal, but tilting the unit will not affect performance.

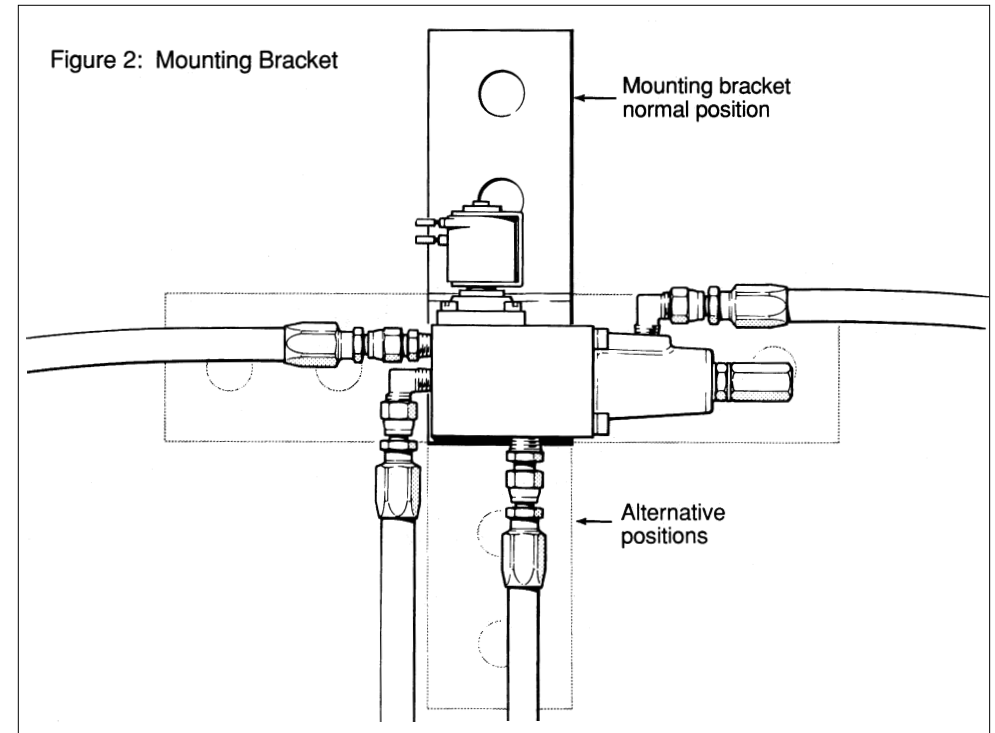

# Fuel Pump

## For AFC type pumps

1. Identify Port 1 (unrestricted rail pressure), and port 2, (gear pump pressure). Remove the two plugs.
2. In Port 2, install an elbow fitting, in Port 1 install the 1/8 NPT extension and then an elbow fitting. Both elbows should point to the rear of the engine.
3. Identify Port 3 (injector supply pressure), which is on the shut down valve. Remove the plug, or on newer engines the Compuchek fitting. Install a tee fitting then a straight fitting pointing to the rear of the engine. Re-install the plug or Compuchek fitting in the other port in the tee.

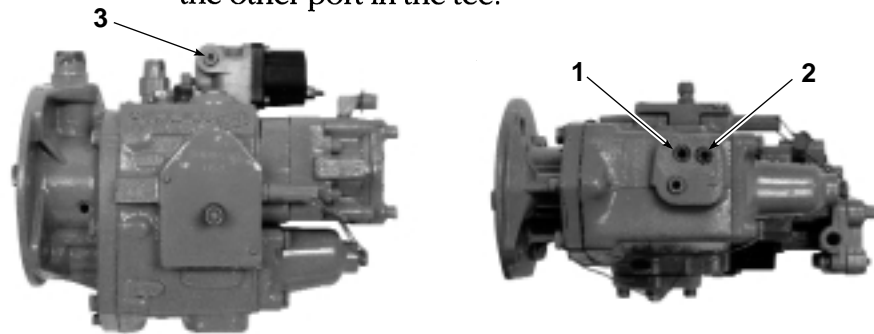

Figure 3: AFC Type Pump

### **NOTE:**

1. If the engine is equipped with STC (step timing control) the Compuchek fitting is installed in a tee above the shut-down valve. Remove this Compuchek fitting, install a tee, then a straight fitting in the tee pointing to the rear of the engine. Re-install the Compuchek fitting in the other port in the tee.
2. Starting in mid 1989 port 2 was changed to SAE-6 O-ring style port. It was 1/8 NPT. Each kit includes an adapter to convert from the O-ring thread to 1/8 NPT thread.

## For NON-AFC type pumps

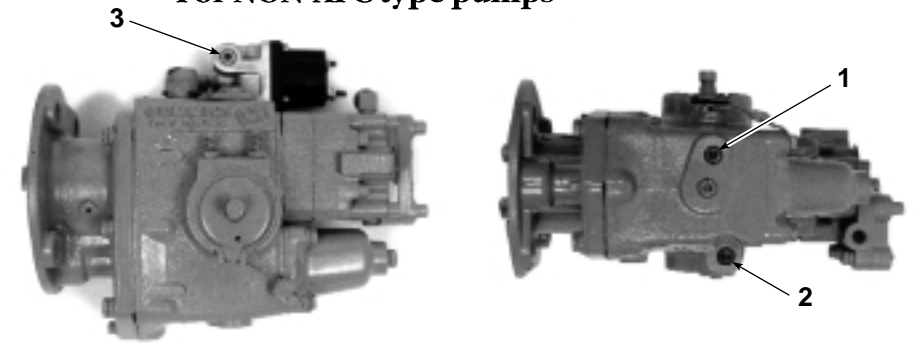

Figure 4: Non-AFC Pump

## For PTG VS Variable Speed pumps

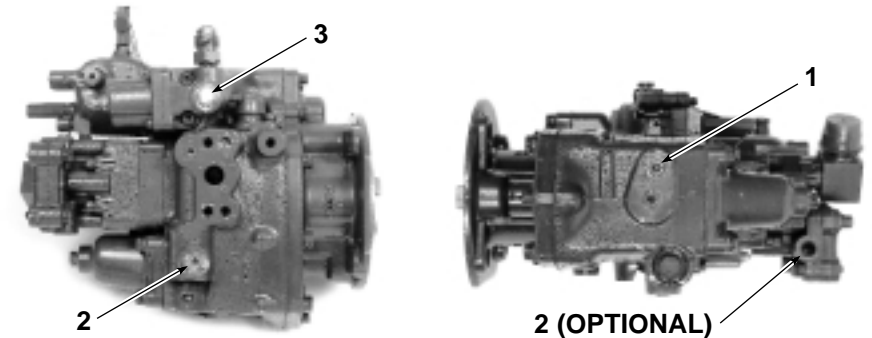

Figure 5: VS Type Pump

### **NOTE:**

- Optional Port 2. Depending on the engine there may not be clearance for a fitting in Port 2. In that case modify the pulsation dampener on the gear pump.
1. Remove the pulsation dampener and disassemble.
  2. Drill a 3/16 hole from the inside groove into the precast port.
  3. Tap the precast port for a 1/8 NPT fitting.
  4. Clean and re-assemble.

## Drain

1. Disconnect the drain hose from the fuel return rail (located near the rear of the engine).
2. Install the #8 male/female adapter fitting on the fuel return rail then attach the drain hose to the adapter.
3. Install a straight fitting in the adapter cross hole nearest to the governor. Plug the other hole.

## Hoses

1. Figure 6 shows the correct method for installing reusable fittings. Examine each hose for obstructions by looking down the centre. Exercise caution to avoid pinching the inner lining.
2. Figure 7 shows how the governor is to be connected to the fuel system. Measure and make up four hoses to make these connections.
3. Flush hoses with diesel fuel. Compressed air will not adequately clean hoses and malfunction may occur.
4. Install hoses as per figure 7.

**CAUTION:** failure to connect the hoses to the correct ports may result in engine RPM run away and subsequent damage to the engine or personal injury. If RPM run away occurs, switch off the governor immediately.

Figure 6: Installing fittings on hose

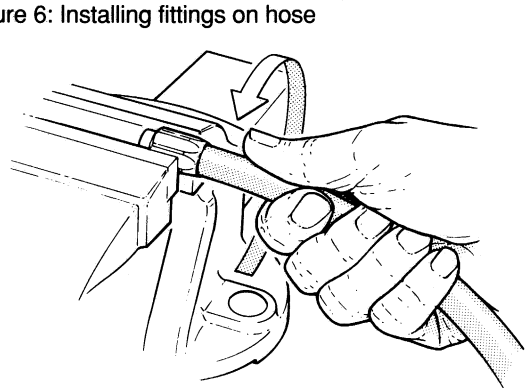

1. Check that inner hose is round, correct if necessary.
2. Place socket in vise.
3. Thread hose counterclockwise until hose bottoms.
4. Back off 1/2 turn.

**NOTE:**

Installing socket will compress inner hose lining making installation of nipple difficult. If this occurs use a lubricated tapered mandrel to increase the inner hose diameter.

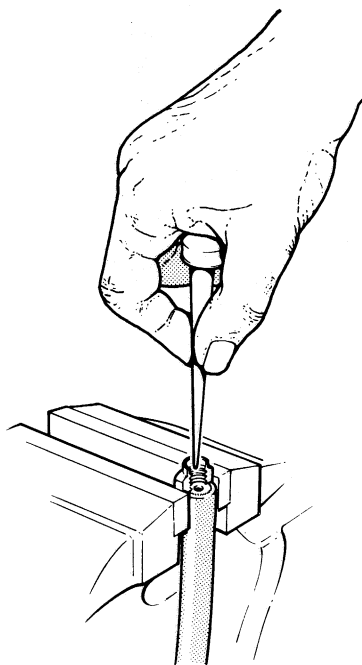

5. Lubricate nipple threads and inside of hose with heavy oil.

**CAUTION:** Do not oil hose cover.

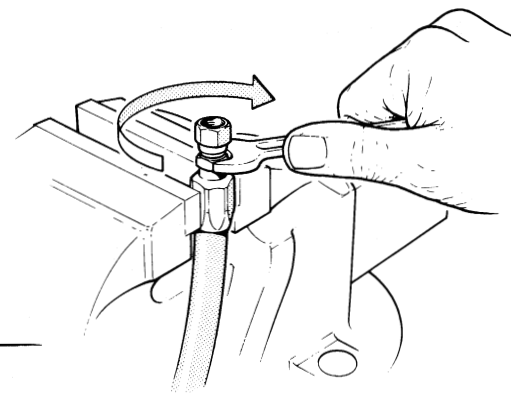
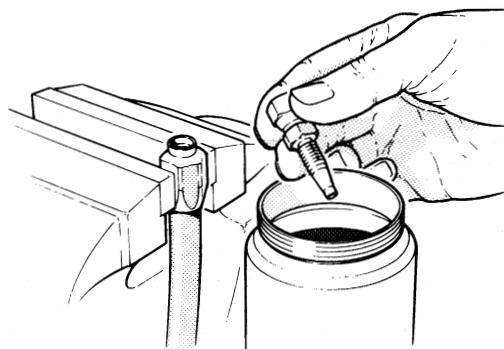

6. Thread nipple clockwise into socket until nipple hex shoulders against socket.

1. Refer to figure 7.
2. Mount the toggle switch in the dash of the cab or other convenient location.
3. For electricity use the same circuit that powers the fuel pump shut down valve. Connect the switch using a fuse for protection.
4. From the solenoid coil, connect one terminal to the switch. Connect the other terminal to the chassis ground.

#### OPTION 1:

#### For engines equipped with a C brake or Jacobs brake.

**WARNING:** *operating the governor and engine brake*

*at the same time may result in engine damage.*

If there is a possibility of this occurring, it is necessary to wire the governor such that when the governor is switched on, the engine brake is switched off. See figure 8 for details.

#### OPTION 2:

#### Throttle lockout for vehicles with power take off equipment.

This option is used to restrict the speed at which power take off equipment is operated. By locking out the throttle the vehicle's driver is no longer able to over rev the engine. See figure 9 for details. A different start-up procedure is required if this option is selected.

Figure 7: Fuel pump - Governor installation

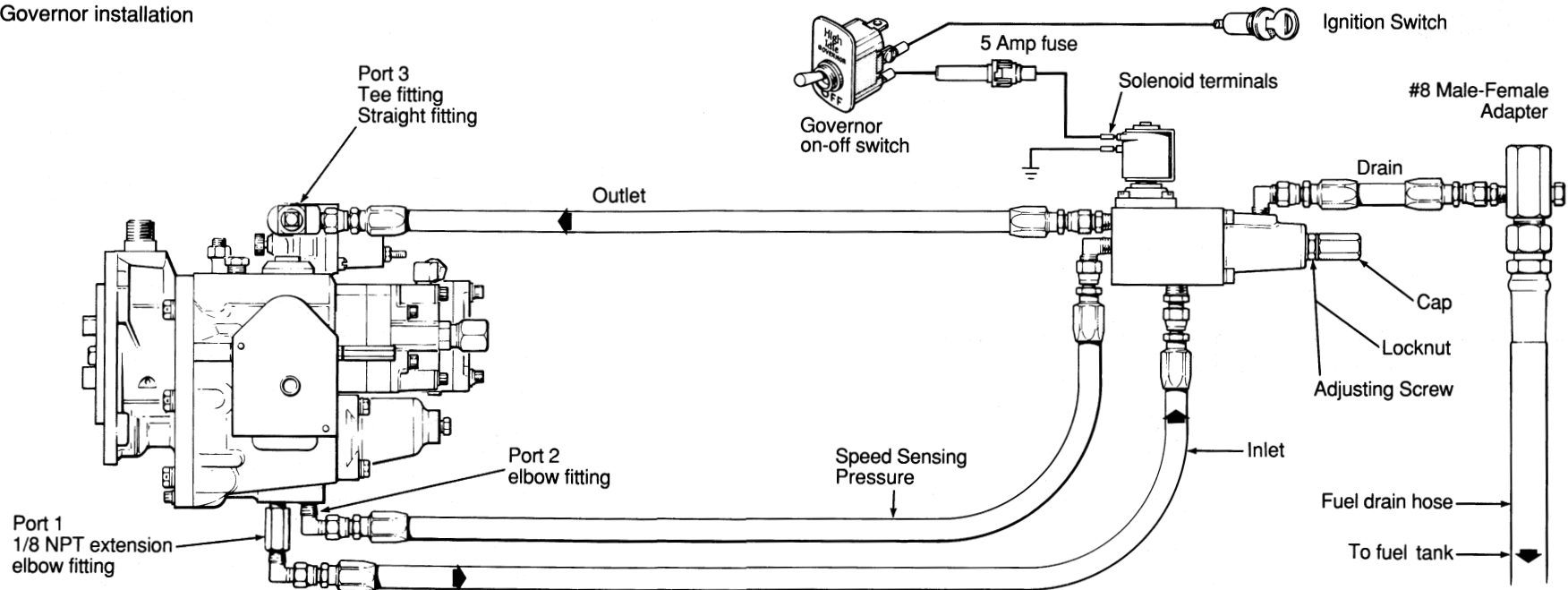

Figure 8: Wiring schematic for engines equipped with a C brake or Jacobs brake

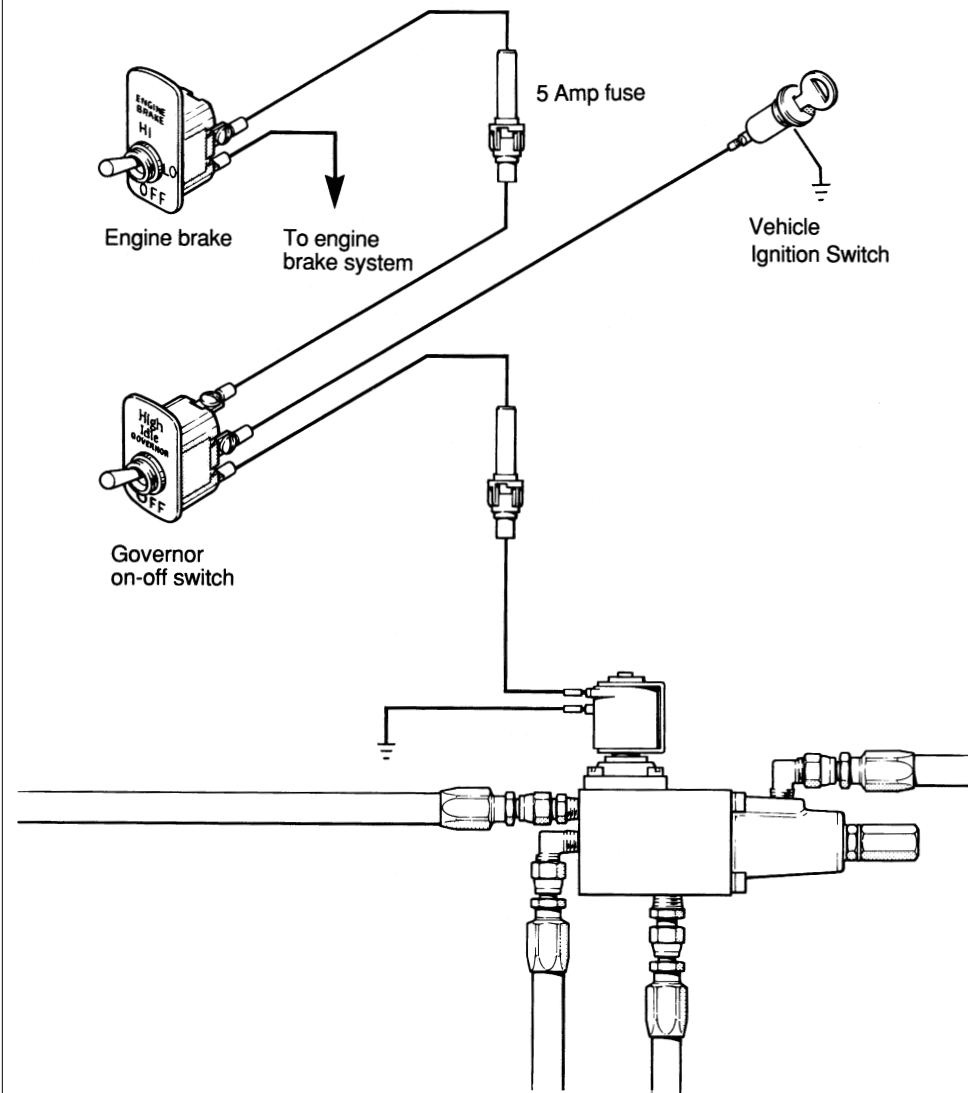
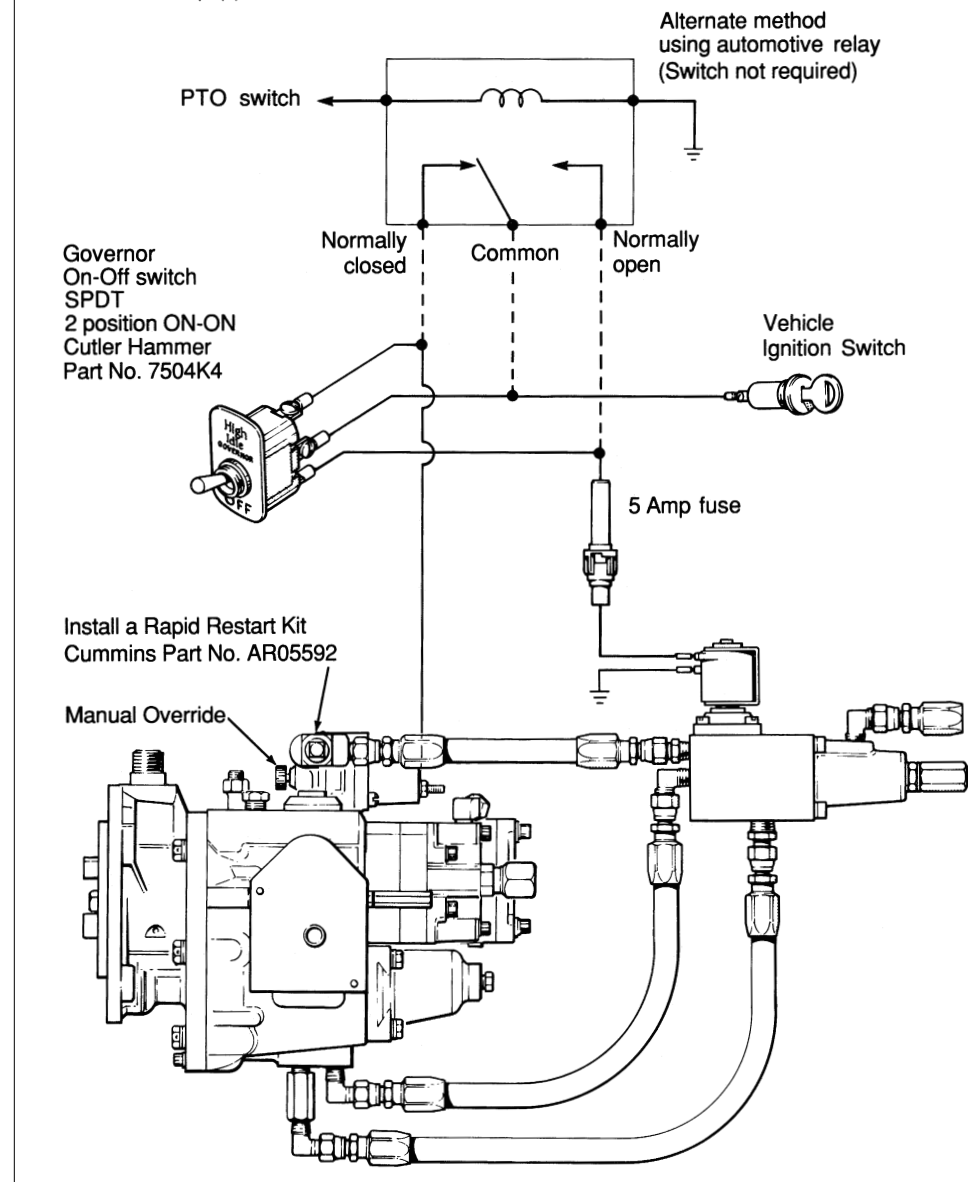

Figure 9: Wiring schematic for throttle lockout on PTO equipped vehicles





1. On the governor, remove the protective cap and loosen the lock nut on the adjusting screw. Back the adjusting screw almost completely out.
2. Start the engine and let it run for several minutes.
3. Switch the governor on.
4. Screw in the adjusting screw until desired RPM is reached.
5. Tighten lock nut and replace cap.
6. Inspect the hoses and fittings for fuel leaks and repair as required.
7. Use the supplied nylon tie wraps on the hoses and wiring to prevent interference and abrasion.

### **OPTION FOR ENGINES WIRED FOR THROTTLE LOCKOUT**

1. On the governor, remove the protective cap and loosen the locknut on the adjusting screw. Back the adjusting screw almost completely out.
2. Turn the manual override screw clockwise on the shut down valve.
3. Start the engine and let it run for several minutes.
4. Switch the governor on.
5. Screw in the adjusting screw until the desired RPM is reached.
6. Tighten the locknut and replace the cap.
7. Inspect the hoses and fittings for fuel leaks and repair as required.
8. Turn the manual override screw counter-clockwise to the off position.
9. Use the supplied nylon tie wraps on the hoses and wiring to prevent interference and abrasion.

## 2. TROUBLESHOOTING

### **Surging or erratic operation. RPM not steady.** see section

Plunger sticking in barrel .....	<b>3-1</b>
Upgrade to new style plunger .....	<b>3-2</b>
Buffer screw not properly adjusted (TR 1001 only) .....	<b>3-3</b>
Contaminated filter screens .....	<b>3-4</b>
Hoses obstructed .....	<b>3-5</b>
Hoses too long .....	<b>3-6</b>

---

### **No power. RPM drops with load, or RPM builds slowly when governor switched on.**

Buffer screw not properly adjusted (TR 1001 only) .....	<b>3-3</b>
Plunger sticking in barrel .....	<b>3-1</b>
Contaminated filter screens .....	<b>3-4</b>
Hoses obstructed .....	<b>3-5</b>
Hoses connected to wrong ports .....	<b>3-7</b>
Wrong model governor installed .....	<b>3-8</b>

---

### **Engine runs at maximum speed.**

Buffer screw not properly adjusted (TR 1001 only) .....	<b>3-3</b>
Spring assembly sleeve not set correctly (TR 2001 only) .....	<b>3-10</b>
Plunger sticking in bore .....	<b>3-1</b>
Contaminated filter screens .....	<b>3-4</b>
Hoses obstructed .....	<b>3-5</b>
Hoses connected to wrong ports .....	<b>3-7</b>
Drain obstructed .....	<b>3-9</b>

## 3. REPAIRS

---

### No response when governor switched on. see section

No electrical power .....	3-13
Coil burnt out .....	3-14
Hoses obstructed .....	3-5
Hoses connected to wrong ports .....	3-7

---

### Leaks at adjusting screw.

Seal washer damaged .....	3-10
---------------------------	------

---

### Leaks at adjusting sleeve.(TR 2001 only)

Spring assembly sleeve not set correctly .....	3-11
Internal O-ring damaged .....	3-12

---

### Will not shut off.

Solenoid valve worn or damaged .....	3-15
--------------------------------------	------

### 1. Plunger sticking in barrel

Inspection: The plunger must drop freely under its own weight from the barrel for correct operation.

1. Remove governor from engine.
2. Disassemble governor, remove all fittings, filters and solenoid valve.
3. Inspect plunger for damage, check that it slides freely.

If the plunger is sticking in the bore, lapping is required.

4. Fit a 6 x 32 machine screw to the tapped hole in the plunger for ease of handling.
5. Use #80 fine lapping compound.
6. Lap the plunger in the barrel.
7. Flush the governor body and plunger thoroughly to remove all lapping compound.
8. Lubricate the plunger with diesel fuel and check that it slides freely.
9. Reassemble governor, install plunger with tapped hole facing the right hand side. (Decal is on front)

### 2. Upgrade to new style of plunger (Early Models Only)

All governors manufactured from April 1987 onwards have a new style plunger which is less sensitive to surging under low power conditions. Units manufactured prior to this change can be identified by the RYTON decal, (newer units are called High Idle Governors), and the date code stamped on the body which will read up to 3-87.

The older governors can be upgraded by fitting a new style plunger. The plunger must be lapped as described in part 1 of this section.

Model #	New plunger part #
TR 1001	417 522
TR 2001	479 321

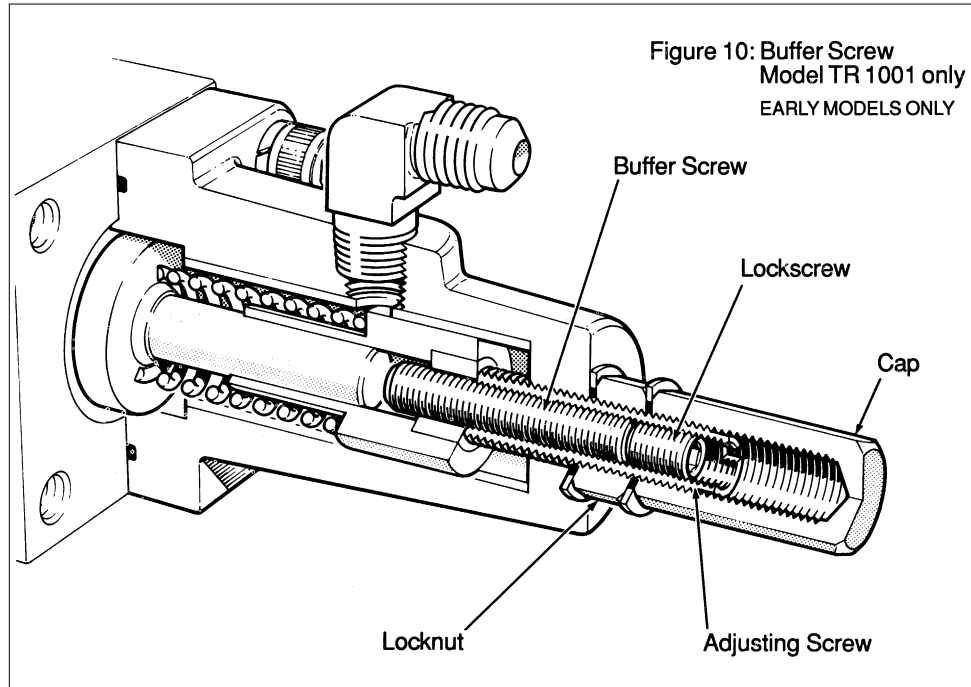

### 3. Buffer screw not adjusted properly (Early Models Only).

Model TR 1001, PTO governors with date codes 1-87 to 9-87 are equipped with a buffer screw. Governors with buffer screws are adjusted as follows. The governor must be installed on the engine (see figure 10).

1. Remove cap, then remove lockscrew (1/4 UNF x 3/8).
2. Back out the buffer screw until it is nearly flush with the adjoining screw. Allow clearance for a screw driver.
3. Start the engine and run for several minutes.
4. Switch governor on and allow hoses to purge themselves of air.
5. Using the adjusting screw, increase engine speed to desired RPM. Tighten locknut.
6. Run engine with governor on until it reaches operating temperature.
7. Set the buffer screw by turning it until the engine speed increases slightly. Back screw off 1/2 turn.
8. If the engine is not running steadily, turn the buffer screw in slightly until surge disappears.
9. Install and tighten lock screw.
10. If RPM increases, buffer screw has turned. Repeat steps 8 and 9.
11. Install and tighten cap.

#### 4. Contaminated filter screens

There are (2) screens in the main body of the governor (see figure 11).

Inlet screen (located behind fitting on bottom of governor).

1. Remove 1/4 NPT fitting at the bottom of the governor.
2. Remove the retaining clip.
3. Extract retaining clip.
4. Install new filter screen.
5. Install new spring.
6. Replace fitting.

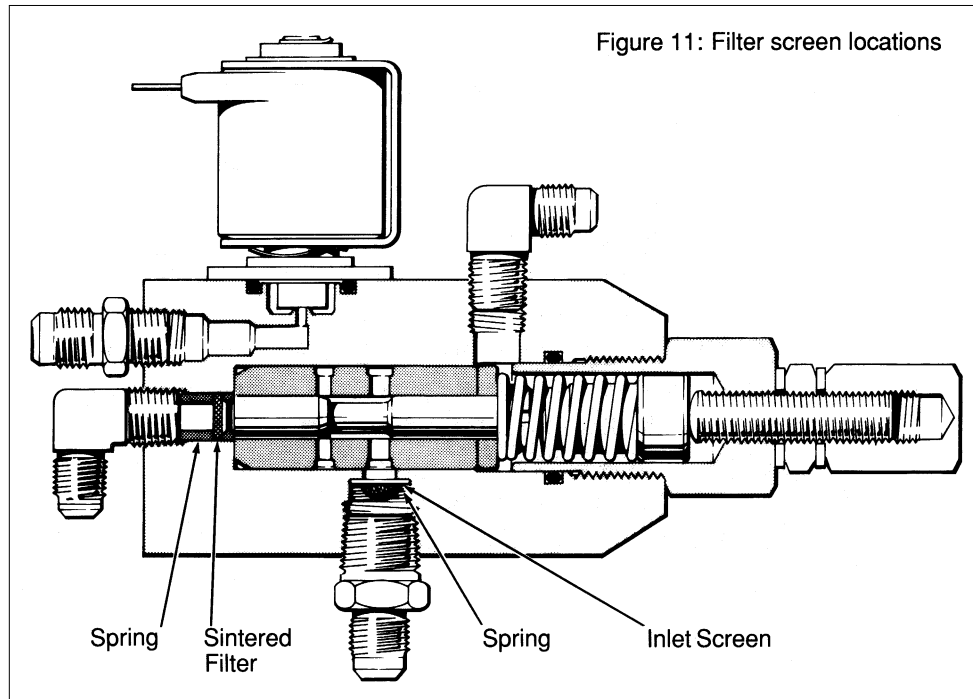

Figure 11: Filter screen locations

Pressure sensing filter (located behind the elbow on left side).

1. Remove straight fitting on upper left side of governor.
2. Remove elbow fitting on left side.
3. Remove the vinyl spacer then the filter.
4. It may be necessary to push the filter out from the opposite side.
5. To reassemble, first install the brass dampening washer.
6. Install a new filter with the round edge leading.
7. Insert vinyl spacer then the elbow.

#### 5. Hose obstructed.

This problem generally occurs when installing the fittings on the hose. Remove the hoses and visually examine each for blockage. If the liner has been pinched, shorten the hose and reinstall the fitting. If the length becomes too short, replace the hose.

#### 6. Hoses connected to wrong ports

Review instructions to ensure the correct fuel pump ports are being used. If your fuel pump is not shown in the instructions, follow these guidelines.

	<b>PT Fuel Pump Port</b>	<b>Teleflex Governor</b>
Connect	Gear pump pressure	to Pressure sensing (left side, lower port)
Connect	Unrestricted rail pressure	to Inlet (bottom port).
Connect	Injector/ rail pressure (at shutdown valve)	to Outlet (left side, upper port).
Connect	Return line to fuel tank	to Drain (top, right port).

## 7. Wrong model governor installed

The model TR 2001 is not recommended for Power-Take-Off. For applications which require more than 30 HP, use the model TR 1001 governor.

## 8. Drain obstructed.

Inspect the following areas for obstruction.

- Drain port on governor.
- Drain hose.
- Adapter fitting in return line to fuel tank.

## 9. Seal washers damaged

Inspect seal washers; if rubber seal is damaged, replace. Be sure to tighten the locknut and protective cap.

## 10. Spring assembly sleeve not set correctly (Early Models Only).

Model TR 2001 governors with date code prior to 4-88 are equipped with an adjustable spring assembly sleeve.

There is an internal O-ring in the body of the TR 2001 governor. The spring assembly must be screwed in until it engages the O-ring. Do not screw in further as it will interfere with governor function (see figure 12).

1. Remove adjusting screw.
2. Loosen large locknut (1-1/4 hex).
3. Back off the spring assembly sleeve (7/8 UNEF thread).
4. Slowly screw in the spring assembly sleeve until you feel resistance from the O-ring.

5. Screw the sleeve in 2 more turns.
6. Check distance from spring assembly sleeve to body, measurement should be 1.16 to 1.22 inches.
7. Tighten locknut.
8. Start the engine and reset the governor speed with the adjusting screw.

## 11. Internal O-ring damaged (model TR 2001 only)

If correctly seating the spring assembly does not stop leakage, it will be necessary to replace the internal O-ring. This is a standard hydraulic O-ring #116-N70. After replacing the O-ring, install the spring assembly sleeve as detailed in part 10 of this section.

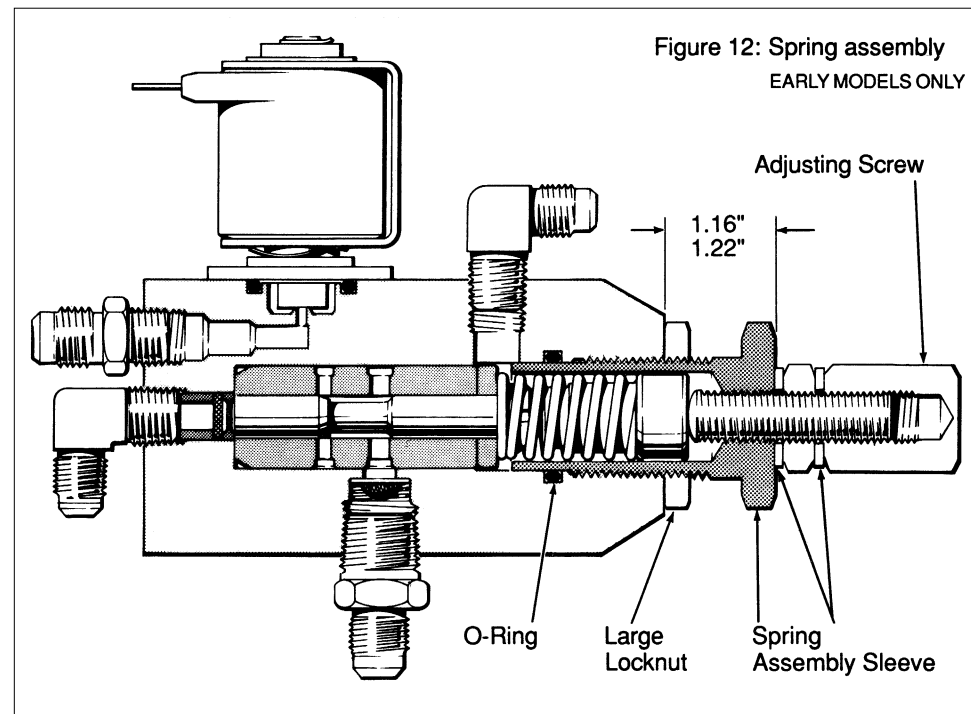

## 4. PARTS LIST

### Installation Kit

#### 12. No electrical power.

Ensure that the solenoid coil is receiving electrical power and also that the coil is grounded.

Check:

- Fuse
- Wire
- Ground

#### 13. Coil burn out.

To test the condition of the coil, measure its electrical resistance. If it exceeds the listed values, replace the coil.

Coil	Resistance
12 VDC	9-13 ohms
24 VDC	55-79 ohms

#### 14. Solenoid valve worn out.

- 1, Remove solenoid valve from governor body.
2. Examine the rubber tip of the plunger for wear.
- 3.(model TR 1001 only). Examine the diaphragm for damage perforations. The diaphragm has two holes in it; one in the centre and one small hole (0.050 diameter) on the side.

Teleflex recommends replacing the entire solenoid valve if these parts are no longer servicable.

#### Models:

PTO Governor, Part No. TR1001  
 PTO Governor, Part No. TR1241  
 High Idle Governor, Part No. TR2001  
 High Idle Governor, Part No. TR2241

#### Part#

#### Qty

#### Description

285829	2	Straight fitting, 1/8 NPT - #4 SAE
285725	3	90° Elbow, 1/8 NPT - #4 SAE
706220	1	Street 'Tee' 1/8 NPT
419725	1	Adapter #8 male-female
419621	1	Adapter 1/8 NPT male-female
700327	7'	Hydraulic hose, SAE 100R5, #5
700421	8	Hose fitting
700524	1	Mounting bracket
700628	2	5/16" NC mounting screw
700721	2	5/16" Lockwasher
700825	1	9/16" NF cap screw
700929	1	9/16" Lockwasher
706821	1	Toggle switch c/w name plate
701122	10'	Wire, 16 gauge
708620	10'	Wire loom
701320	2	Solderless connector; female disconnect
701423	2	Solderless connector; ring for #10 stud
705123	2	Solderless connector; ring for #6 stud
701527	1	Inline fuse holder
701621	1	5 amp fuse
701724	6	Nylon cable tie
TP1060	1	Adapter -3 ORB to 1/8 NPT
TP1061	1	Adapter PT - Pacer -5 ORB

## TR-1001 & TR-1241

1. Solenoid Valve 10-QW2, 12 Volt DC \_\_\_\_ Part# TP-1040
2. Solenoid Valve 10-QW2, 24 Volt DC \_\_\_\_ Part# TP-1041
3. Coil, 12 Volt DC \_\_\_\_\_ Part# TP-1034
4. Coil, 24 Volt DC \_\_\_\_\_ Part# TP-1035
5. Solenoid Valve Repair Kit \_\_\_\_\_ Part# TP-1036
6. Rebuild Kit for TR-1001 & TR-2001 \_\_\_\_ Part# TP-1050

Kit includes following:

Item	Description
a _____	Spring
b _____	Sintered Filter
c _____	Spring
d _____	Inlet Screen
e _____	Seal Ring (TR-1001 only)
f _____	Seal Washer (2)
-	O-ring (TR-2001 only)

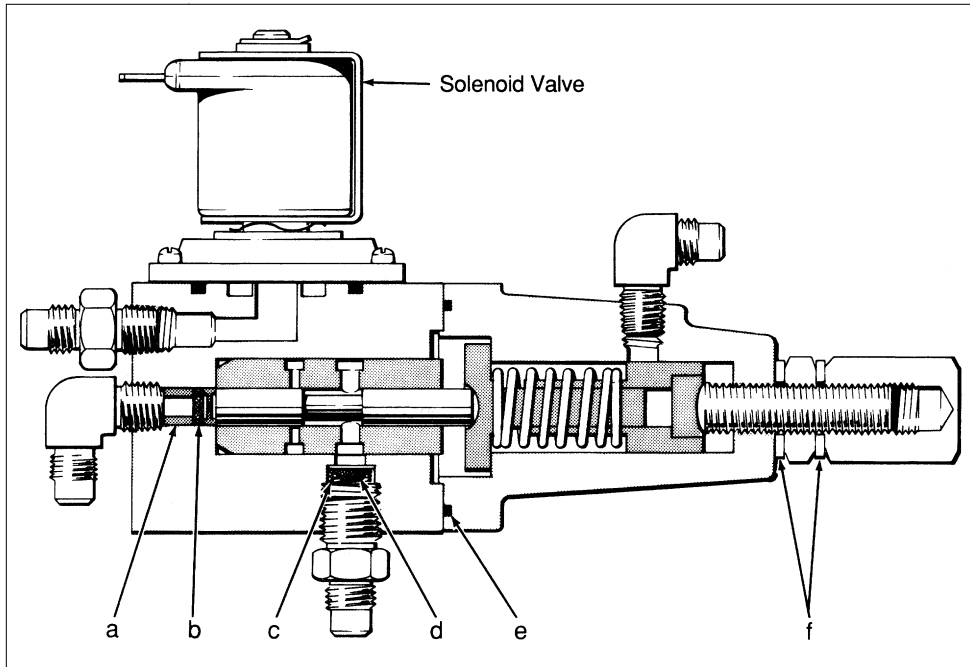

## TR-2001 & TR-2241

1. Solenoid Valve 1-Q3M, 12 Volt DC \_\_\_\_ Part# TP-2020
2. Solenoid Valve 1-Q3M, 24 Volt DC \_\_\_\_ Part# TP-2021
3. Coil, 12 Volt DC \_\_\_\_\_ Part# TP-1034
4. Coil, 24 Volt DC \_\_\_\_\_ Part# TP-1035
5. Solenoid Valve Repair Kit \_\_\_\_\_ Part# TP-2041
6. Rebuild Kit for TR-1001 & TR-2001 \_\_\_\_ Part# TP-1050

Kit includes following:

Item	Description
a _____	Spring
b _____	Sintered Filter
c _____	Spring
d _____	Inlet Screen
e _____	O-ring #116-70D (TR-2001 only)
f _____	Seal Washer (2)
-	Seal Ring (TR-1001 only)

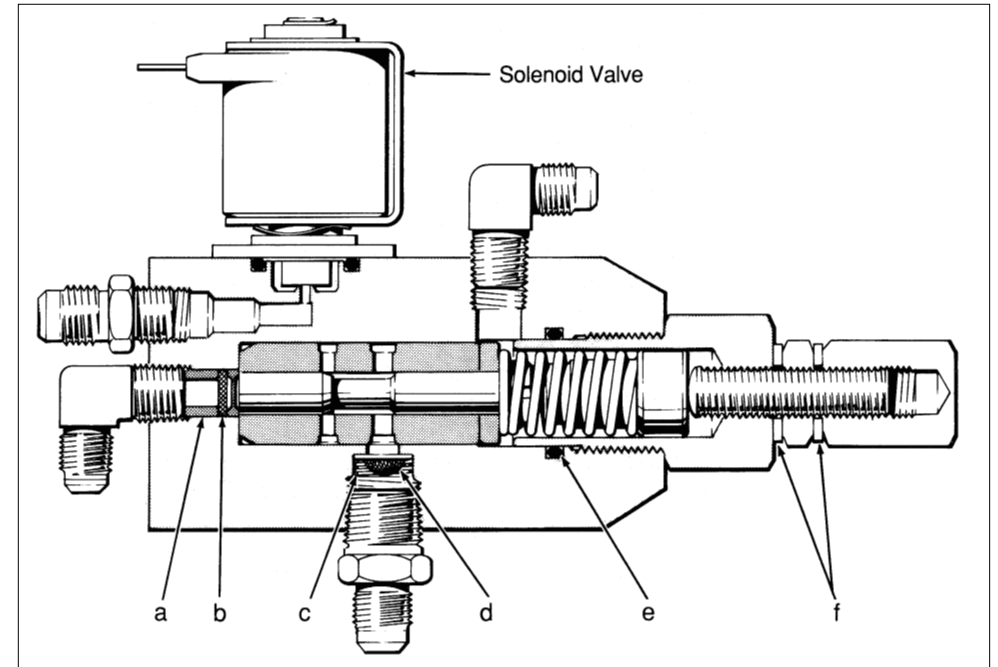

## One Year Limited Warranty

Teleflex warrants to the original retail purchaser that the High Idle Governor furnished hereunder will conform to Teleflex specifications and to be free from defects in materials and workmanship. This warranty applies to normal recommended use and service and will be effective for a period of one (1) year from the date of original retail purchase. This warranty will be void if the product is modified in any way or not used in accordance with the instructions.

The foregoing warranty is exclusive and in lieu of all other warranties, guarantees, or representations, whether oral, written or implied, including any warranty of merchantability or fitness for use or purpose. Purchaser by accepting delivery of the product, thereby waives reliance on any other such warranties.

Teleflex's sole obligation under the foregoing warranty and otherwise will be to replace any defective Governor returned to Teleflex with our approval, freight prepaid, within one year from the date of purchase by the end user, which shall be the Purchaser's exclusive remedy. In no event shall Teleflex be liable to the Purchaser for any incidental, special or consequential damages.

Teleflex will allow labour charges up to a maximum of one (1) hour for removal and replacement of the defective unit. No claim will be accepted for readjustment of a governor. Any Teleflex High Idle Governor replaced under this warranty shall be warranted for the unexpired portion of the original warranty period.

1. Should a problem occur with a Teleflex High Idle Governor that is within the warranty period Teleflex recommends immediate replacement of the unit.
2. Contact Customer Service at (604) 270 6899 for authorization and Claim No.