

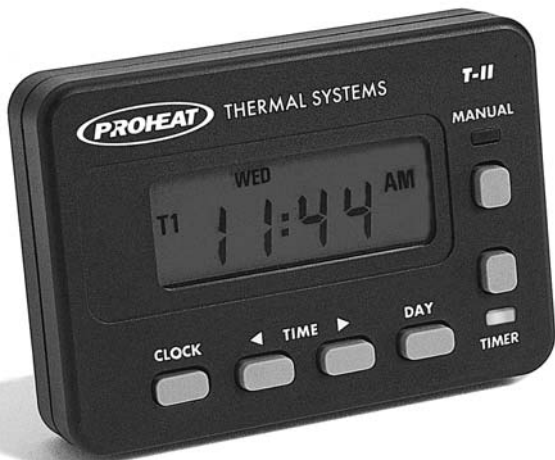

T-II TIMER

INSTALLATION & OPERATING INSTRUCTIONS

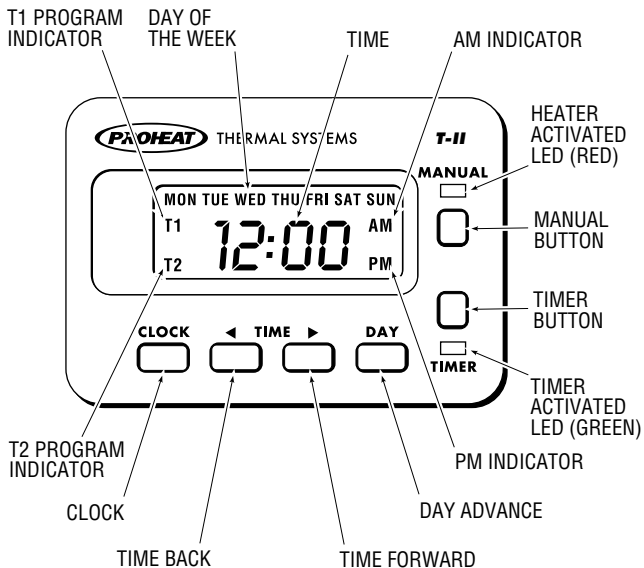



General Description

The Proheat T-II 7 Day Digital Timer Features include:

- Two Timer Modes Available
 - Single Timer Mode (T1). Used for a single start time, one day per week.
 - Dual Timer Mode (T1 and/or T2). Used one or two times per day, 1, 5, 6 or 7 days per week with automatic reset.
- Run time duration in Timer Mode can be preset for 1 or 3 hours
- Lockout Mode used to prevent unauthorized changes to all settings and Timer programs.
- Stored Timer programs and all user settings remain set in memory in the event of a power loss.
- Manual Mode with user settable maximum runtime
- Heater Diagnostic Codes displayed on LCD.
- 12 or 24 hour time display
- 12 or 24 volt automatic operation
- Backlit LCD

Installation

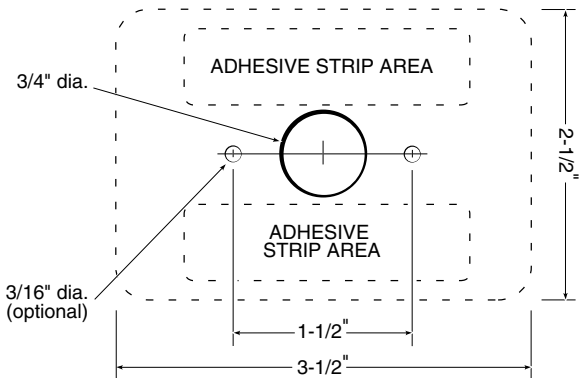

Dash Surface Mount

- Step 1** Drill 3/4" diameter hole in centre of mounting area for connecting wires.
- Step 2** Use self adhesive strips to attach Timer to surface.
- OR** Drill 3/16" diameter holes (optional) according to diagram for mounting with studs and nuts.

Below Dash

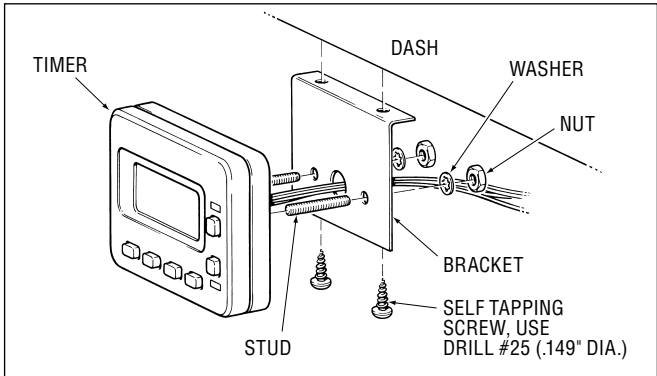

Gauge Hole

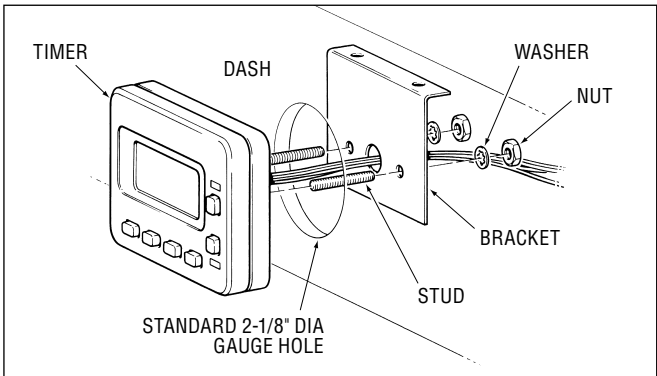

Wiring & Dip Switch Settings

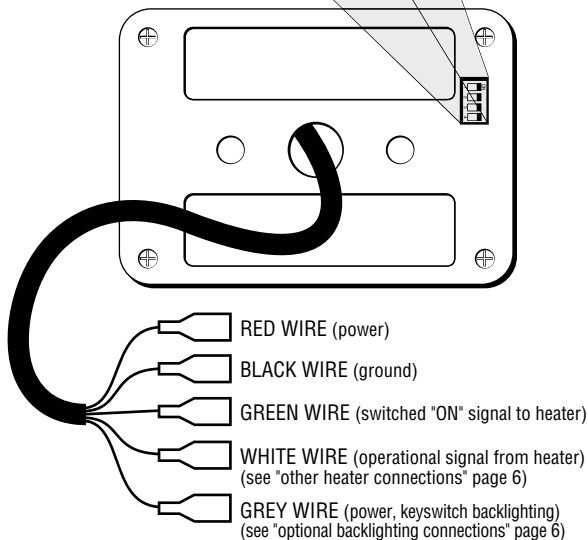
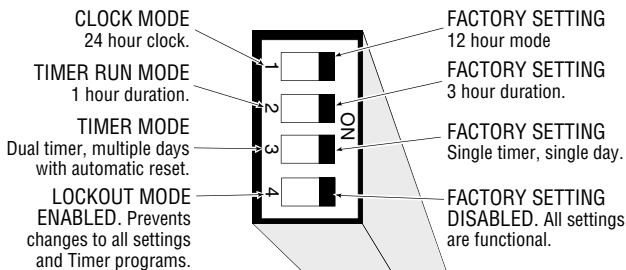

Timer Wiring

PROHEAT Heater Connection

CAUTION

Power to the Heater must be disconnected before connecting the Timer.

Connect the Proheat Heater switch harness wires to the Timer as follows:

- Black to Black
- Green to Green
- White to White
- Red to Red

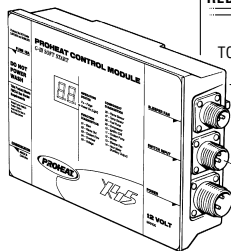
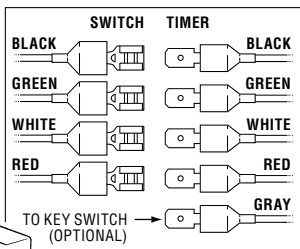

CAUTION

Miswiring the Timer connections may result in Timer damage & incorrect operation.

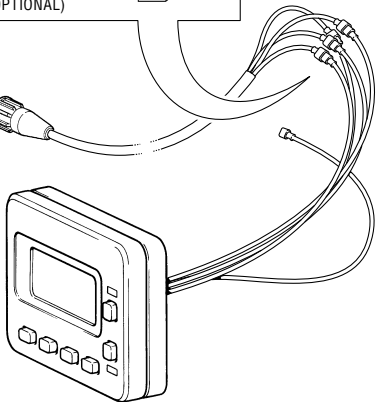

Optional Backlighting Connections

The gray Timer wire can be connected to any key switched power source so the Backlighting will be on anytime the key switch is on.

Other Heater Connections

If the Timer is connected to a heater which does not have an operational signal wire, then the white Timer wire must be jumpered to the green "ON signal" wire in order for the Timer's red "ON" LED to light. No codes will be displayed if the Timer is wired in this manner.

Power Up

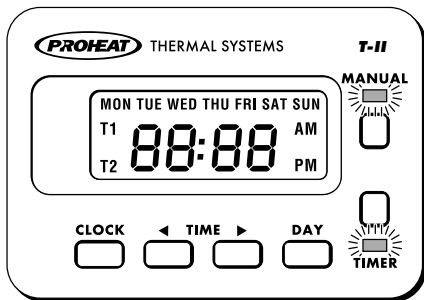

12 Hour Mode



24 Hour Mode



When power is first applied to the Timer or if power is lost then restored, you will see the above segment test screen along with the Red & Green LED's illuminated for 2 seconds.

The screen will then change to one of the continuously flashing Clock screens, shown left (Based on the **Clock Mode** dip switch #1, factory preset: 12 hour mode) and will stay this way until the Time of Day is set.

NOTICE

If the Lockout Mode dip switch #4 is in the ENABLED position, you may see T1 and/or T2 and the Green LED illuminated (if previously enabled). See "Lockout Mode" page 12.

To Set Clock – Time & Day

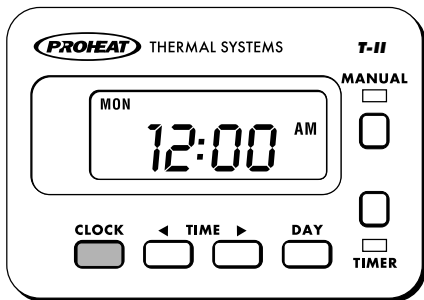

- STEP 1** Press & Hold **“Clock”**.
- STEP 2** Press **“←”** or **“→”** to set time.
- STEP 3** Press **“Day”** to set day.
- STEP 4** Release **“Clock”**.

NOTICE

See page 4 for optional Clock Mode settings.

To Set Single Timer

Single Timer, Single Day Mode

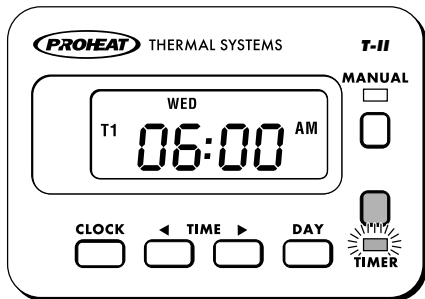

Timer set in single timer mode only will allow you to set one “ON” time one day per week and has to be manually reactivated. With the T1 time activated, the Timer will go “ON” at the preset time (Red and Green LED’s on), and will be deactivated at the end of it’s duration time. To reactivate the Timer press “**Timer**”.

- STEP 1** Press & Hold “**Timer**”.
(Green LED will go on & “T1” will flash.)
- STEP 2** Press “◀” or “▶” to set “ON” time.
- STEP 3** Press “**Day**” repeatedly to set day.
- STEP 4** Release “**Timer**”. (Green LED and “T1” will remain lit to indicate active Timer.)

NOTICE

See page 4 for optional Timer Mode settings.

Example

Highway Truck parked for the weekend. Set Timer T1 at 6:00 a.m. for Monday. The heater will switch on one time only and run for 1 or 3 hours (see page 4 Timer Run Mode settings) and preheat Truck on Monday morning before the driver arrives at 7:00 a.m.

To Set Dual Timer

Dual Timer, Multiple Day Mode

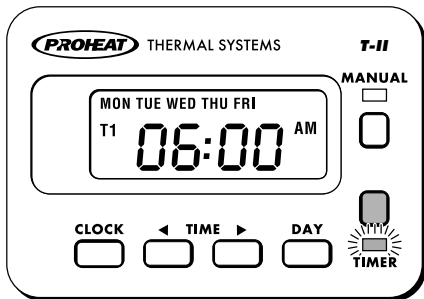

In the dual timer mode setting you can program your Timer to come “ON” one day per week or, Mon. thru Fri., Mon. thru Sat or Mon. thru Sun. It also has a built in automatic reset function so that you do not have to re-activate the Timer after every duration time.

NOTICE

See page 4 for optional Timer Mode settings.

- STEP 1** Press & Hold **“Timer”**.
(Green LED will go on & “T1” will flash.)
- STEP 2** Press **“◀”** or **“▶”** to set “ON” time.
- STEP 3** Press **“Day”** repeatedly to set day(s).
- STEP 4** Release **“Timer”**. (Green LED and “T1” will remain lit to indicate active T1 program.)
T1 program is now activated.
Follow steps 5 thru 8 for T2 program. (Optional)
- STEP 5** Press & Hold **“Timer”**.
(Green LED will remain on & “T2” will flash.)

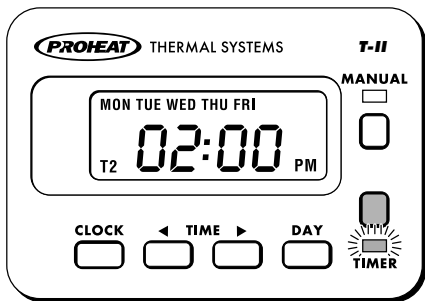

- STEP 6** Press “◀” or “▶” to set “ON” time.
- STEP 7** Press “Day” repeatedly to set day(s).
- STEP 8** Release “Timer”. (Green LED and “T2” will remain lit to indicate active T2 program.)
- STEP 9** Press “Timer” once more to activate both “T1” & “T2”. (“T1” and “T2” will remain lit to indicate active “T1” and “T2” program.)
- You can toggle through to activate or deactivate the T1, T2 and T1 + T2 Timers by repeatedly pressing “Timer”.

NOTICE

Timer will repeat each set day until switched off.

Example

School bus Timer: T1 is set at 6:00 a.m. Mon. through Fri. T2 is set at 2:00 p.m. Mon. through Fri. The heater will switch on each weekday morning at 6 a.m. and run for 1 or 3 hours (see page 4 Timer Run Mode settings) then switch off. The heater will again switch on at 2 p.m. each weekday afternoon and run for 1 or 3 hours (see page 4 Timer Run Mode settings) then switch off. This will automatically repeat every weekday until the Timer is switched off.

Lockout Mode

Used to prevent unauthorized changes to the Clock, Timer (Single and Dual modes) program time settings, Timer Active (On/Off) state and Manual Mode Runtime settings.

Timer (Single and Dual modes) program settings, Timer Active (On/Off) state and Manual Mode Runtime settings will remain set in memory in the event of a power loss. However the Clock will have to be set before the Timer will function once power is resorted. The Clock setting function will go into Lockout Mode 5 minutes after the Clock button is pressed (time stops flashing) and the time is set.

You will see this screen while pressing any button in Lockout Mode, except for the **Manual** button. The **Manual** button will function in Lockout Mode.

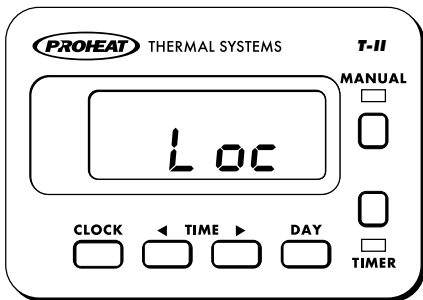

NOTICE

See page 4 for optional Lockout Mode settings.

Manual Mode Runtime

Used to set the maximum runtime the heater will operate when heater is switched on by pressing the **Manual** button.

To enter the Manual Mode Runtime settings

- Step 1** Press and hold the **Clock** and **Timer** buttons simultaneously for 5 seconds.

The current software version will display briefly:

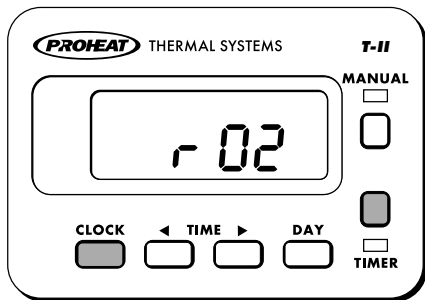

While still holding **Clock** and **Timer**, the following screen will be displayed:

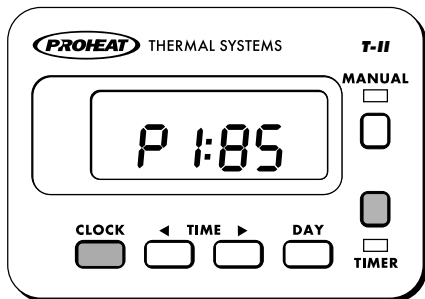

Step 2 Release the **Clock** and **Timer** buttons.

Step 3 Use the “◀” or “▶” to set the desired maximum runtime in half hour increments from 0.5 hours to 9.5 hours.

Example *P1:05 = 0.5 hours.*
P1:10 = 1.0 hours.
....
P1:95 = 9.5 hours.

P1:00 = infinite (no maximum) Factory Setting.

With this setting the heater will operate indefinitely until it is switched off.

Step 4 Press the **Clock & Timer** buttons simultaneously to exit Manual Mode Runtime Settings.

NOTICE

To enter Manual Mode Runtime settings Lockout Mode must be DISABLED. See page 4 for Lockout Mode settings.

Manual Heater Operation

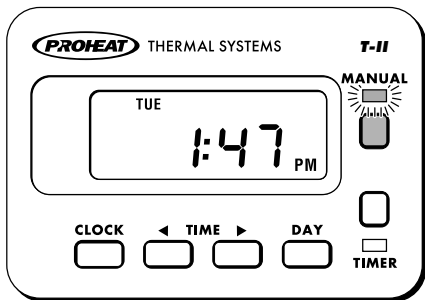

The “**Manual**” button is used to turn the heater on and off when desired regardless of set Timers.

- STEP 1** Press “**Manual**” to activate the heater. (Red LED will go on and the heater will operate indefinitely (factory preset) or up to 9.5 hours if Manual Mode Runtime is set.)
- STEP 2** Press “**Manual**” again to de-activate the heater. (Red LED will go out and the heater will turn off.)

“Manual” & “Timer” cannot be active at the same time. If “Manual” is active and “Timer” is pressed, the heater will turn off and the Red Manual LED will go out.

Timed Heater Operation

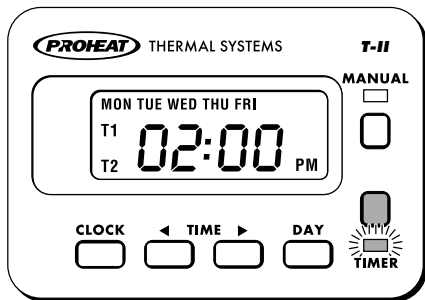

Single Timer Single Day Mode

- STEP 1** Press **“Timer”** to activate the T1 program (Green Timer LED will go on). The Heater will switch on at the set T1 program time and run for 1 or 3 hours (see page 4 Timer Run Mode settings) then switch off. The Green Timer LED will now be out. To set Timer T1 again for the same time and day repeat step 1.
- STEP 2** Press **“Timer”** to deactivate and cancel the current T1 program (Green Timer LED will go out).

If **“Timer”** is active and **“Manual”** is pressed, **“Timer”** is de-activated and green LED goes out.

When the heater has been turned on by the **“T1 Timer”** in single timer mode, the heater can be turned off by pressing either **“Manual”** or **“Timer”**. Both red and green LED's will go out. If Lockout Mode is ENABLED only the **“Manual”** button will work.

Dual Timer, Multiple Day Mode

- STEP 1** Press **“Timer”** repeatedly to toggle through and activate T1, T2 and T1 + T2 Timers. (Green Timer LED will go on). The Heater will switch on at the set program(s) time and run for 1 or 3 hours (see page 4 Timer Run Mode settings) then switch off. The Timer will then automatically repeat each set program until switched off.
- STEP 2** Press **“Timer”** repeatedly to toggle through and deactivate and cancel the current set program(s) (Green Timer LED will go out). T1, T2 and T1 + T2 Timers. (Green Timer LED will go off).

If the heater has been turned on by the “T1 or T2 Timer” in dual timer mode, pressing “Manual” will turn the heater off but leaves the Timer(s) activated. Pressing “Timer” will turn off the heater and de-activate the Timer(s). If Lockout Mode is ENABLED, only the “Manual” button will work.

NOTICE

See page 4 for optional Timer Mode settings.

To activate or deactivate Timer programs Dip switch #4 Lockout Mode must be DISABLED. See page 4 for Lockout Mode settings.

Diagnostics

When the Timer is connected to a PROHEAT heater, The Timer's red "Heater Activated LED" will be lit constantly while the heater is running normally. In case of heater error, the Timer's red LED will flash an error code, followed by a pause. The error code will also be displayed on the LCD in the form "Er XX". These errors correspond to those displayed on the PROHEAT Control Module (PCM) diagnostic panel.

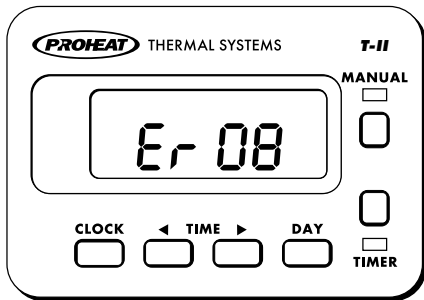

Example *On an M-Series heater a repeatedly flashing eight pulses separated by a pause indicates a heater Fuel Shut-Off Valve error.*

Please see the heater service manual for the Complete listing of all heater error codes, their meaning and Troubleshooting procedures. Available for download at www.proheat.com

| M-Series | X-45 |
|------------------------------------|--------------------------------|
| 1 Start Error | 1 Start Error |
| 2 Flame Out | 2 Flame Out |
| 3 Coolant Flow | 3 Coolant Flow |
| 4 Overheat | 4 Overheat |
| 5 Voltage | 5 Voltage |
| 6 Flame Fault | 6 Flame Sensor |
| 7 Temp Sensor | 7 Temp Sensor |
| 8 Fuel Shut-Off Valve | 8 Fuel Pump |
| 9 Temp Sensor T2 (G-I PCM Only) | 9 Compressor |
| 10 Ignition Module | 10 Ignition coil |
| 11 Coolant Pump | 11 Coolant pump |
| 12 Motor | 12 Blower |
| 13 Aux. Output | 13 Sleeper Fan/ Aux. output |
| 14 Switch Output | |
| 15 Indicator Output | |
| 16 System Current | |
| 17 Motor Speed Error | |
| 18 CANbus Error | |

Warranty Policy

SeaStar Solutions warrants the Proheat T-II Timer to be free from defects in material and workmanship under normal use and service for two (2) years on parts and labor from the date of first installation. Replacement parts are warranted the remainder of the Timer's warranty or 90 days, whichever is longer. **This warranty applies only to those units which are installed by a registered PROHEAT dealer.** All labor charges will be paid in accordance with SeaStar Solutions' published Standard Repair Time (SRT) guidelines.

THE WARRANTIES SET FORTH HEREIN ARE THE SOLE WARRANTIES MADE BY SEASTAR SOLUTIONS IN REGARD TO THE PROHEAT T-II TIMER KIT SEASTAR SOLUTIONS MAKES NO OTHER WARRANTIES, EXPRESS OR IMPLIED, OR OF MERCHANTABILITY OR FITNESS FOR A PARTICULAR PURPOSE.

OWNER RESPONSIBILITIES

Before the expiration of the warranty, Owner must give notice to a registered PROHEAT dealer of failures, if any, considered to be warrantable and deliver the defective Timer to such dealer. Owner is responsible for the cost of all repairs made to the engine or equipment in which it is installed, other than the Proheat T-II Timer Kit. Owner is responsible for lodging, meals and incidental costs incurred by the Owner as a result of a warrantable failure. Owner is responsible for 'down-time' expenses, and all business costs and losses resulting from a warrantable failure. **SEASTAR SOLUTIONS IS NOT RESPONSIBLE FOR INCIDENTAL OR CONSEQUENTIAL DAMAGES.**

NOTICE

This is a warranty summary. For the complete warranty manual please go to www.proheat.com



SeaStar Solutions

3831 No. 6 Road
Richmond, B.C.
Canada V6V 1P6

Tel: 604-270-6899

Fax: 604-270-7172

www.proheat.com

© 2011 Marine Canada Acquisition Inc.
DBA SEASTAR SOLUTIONS

Printed in Canada

PID# 958829C 03/14